



DISPENSERS



PUMPS



METERS



METERED NOZZLES



NOZZLES

# THREE25

## FEATURES

- SPECIFICALLY DESIGNED FOR IBC TANKS
- SUZZARABLU DIAPHRAGM PUMP
- EASY TO INSTALL / REPLACE THE IBC TANK
- AUTOMATIC NOZZLE
- BUILT-IN FILTER

PIUSI Three25 is the most famous DEF dispenser worldwide for IBC tanks. It comes with the SuzzaraBlue pump, the SB325 automatic nozzle, the 3D filter, and the PIUSI dispense coupler.

## PERFORMANCE

UP TO  
**9 GPM**

FLOW RATE

AC/DC  
**120/60 - 12VDC**

POWER

**20 FT**

HOSE LENGTH

**20 MIN**

DUTY CYCLE



THREE25



## PACKAGING

PART #	WEIGHT		PACKAGING		
	KG	LBS	MM	INCH	PCS/BOX
FOO101AOA	14.5	32	480X390X310	19.3X15.4X12.2	1
FOO101A1A	12.7	28	480X390X310	19.3X15.4X12.2	1



FILTRATION



FLUID MONITORING



HOSE REELS



ACCESSORIES



AIR



ANTIFREEZE



DEF



BIODIESEL



DIESEL



FOOD



GASOLINE



GREASE



KEROSENE



OIL



WATER



WINDSCREEN

## CHARTS

### SUZZARABLUE AC/DC

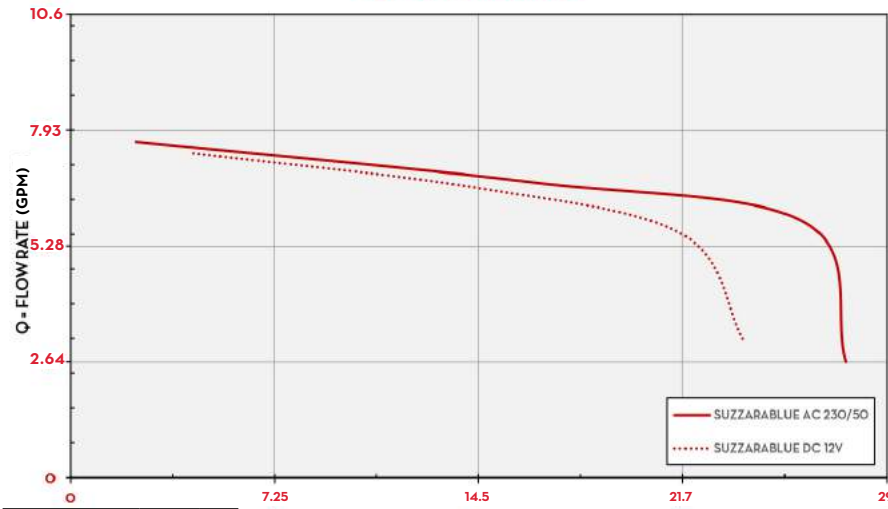

TYPE OF FLUID WATER  
TEMPERATURE 68 °F

## IN THE BOX

- THREE25 UNIT
- SUCTION / DELIVERY HOSE
- SB325\_X NOZZLE
- INSTRUCTION MANUAL

## DETAILS



PDC COUPLER



TROLLEY CART AVAILABLE (PG. 42)



K24 METER



NOZZLE

## DIMENSIONS

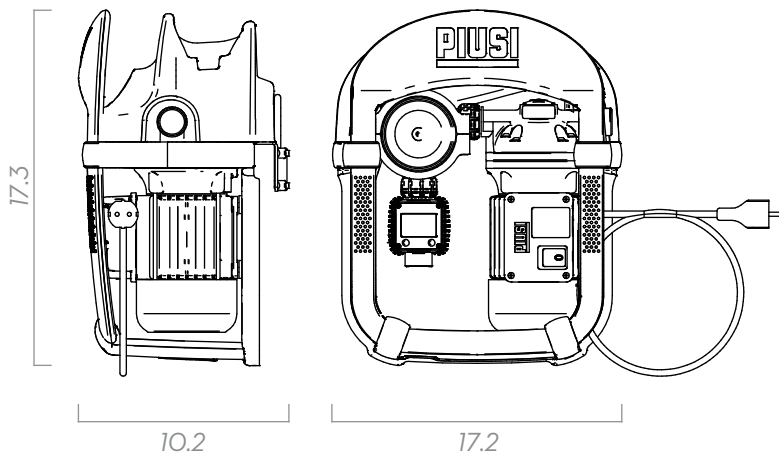

Dimensions expressed in inches

## MATERIALS

- **PUMP:**  
SUZZARABLUE PUMP AC PG. 28
- **METER:**  
K24 METER PG. 46
- **NOZZLE:**  
SB325\_X METER PG. 56
- **FILTER:**  
3D FILTER PG. 72

## TECHNICAL DATA

PART #	DESCRIPTION	FLUIDS TYPE	FLOW RATE		VOLTAGE			METER	NOZZLE	SUCTION	HOSE LENGTH Ø 3/4"	ON/OFF SWITCH
			L/MIN	GPM	AC V/HZ DC VOLT	POWER WATT	AMP. MAX.					
FOO101A0H	THREE25 120V (AUTO/METER/FILTER/PDC)		32	9	120/60	370	2	K24	SB325_X METER	SEC	20 FT	YES
FOO101A1A	THREE25 12V (AUTO/METER/FILTER/PDC)		32	9	12	260	22	-	SB325_X METER	SEC	20 FT	YES